

SINCE 1980



Bhaskara Group

RECOGNISED FOR INNOVATIVE PRODUCTS

6

PUSH / PULL ATTACHMENT

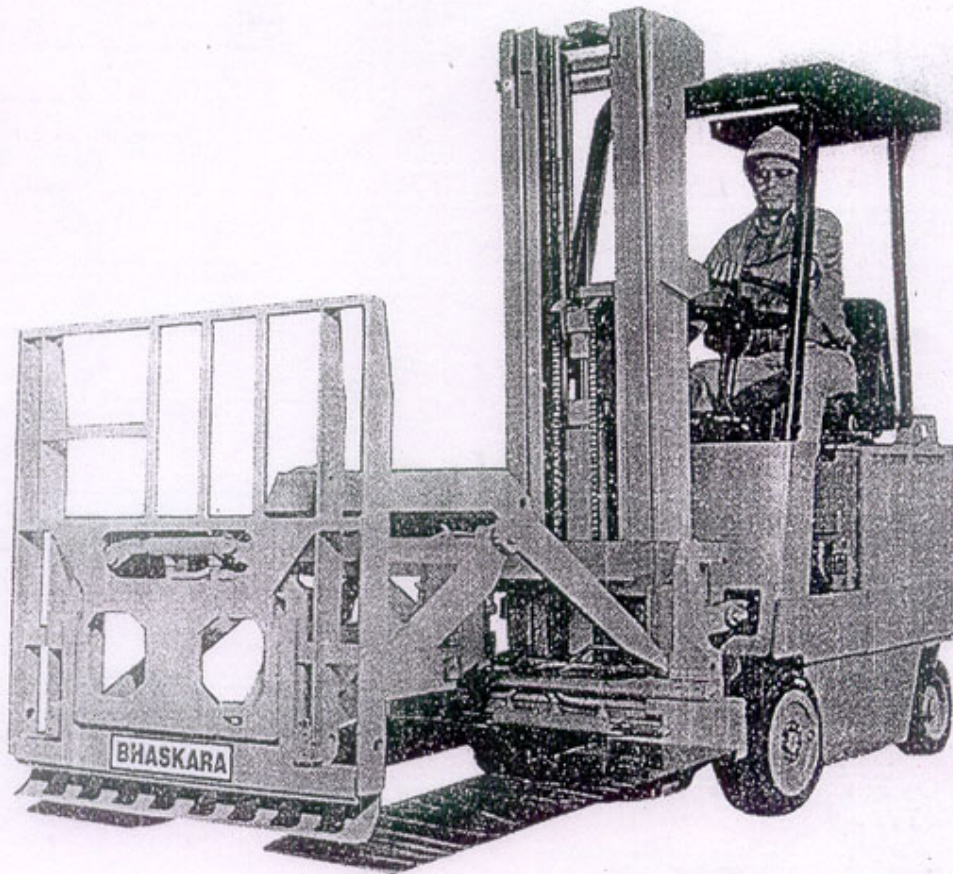

**THERE ARE NO CONDITIONS
THAT WE CAN'T HANDLE AND
YOU WILL LOVE OUR GUTTS**

**BHASKARA
ADVANCED
AUTOMATION**
Bangalore - 560 021, INDIA

Pantograph type attachments

"EASY RIDER" fork mounted load Push-Pull

Thanks to the extremely quick fitting system, "EASY RIDER" offers the possibility to convert a conventional lift truck into a special machine equipped to handle loads on sheet.

The truck driver just has to enter the forks into the pockets in the platens and lock the frame by means of two simple sliding pins. Quick release couplings connect the hydraulic circuit to the lift truck. In a few seconds the truck is ready for use.

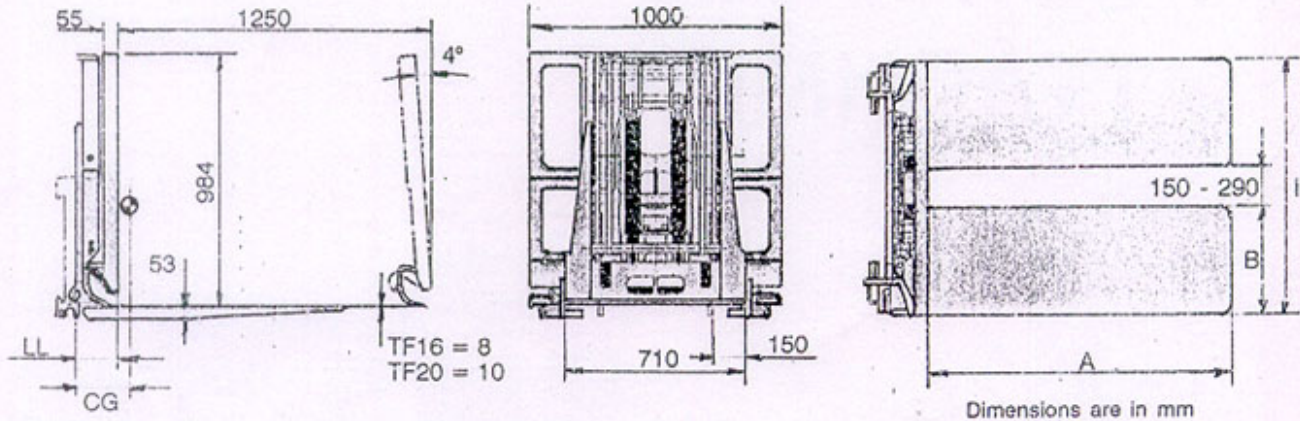
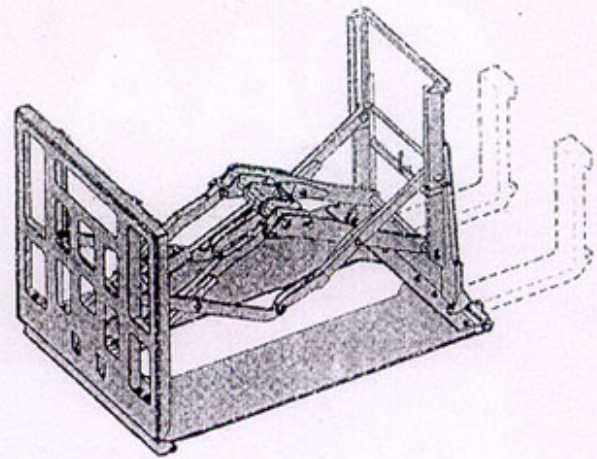

"EASYSIDER" Push-Pull - 1 Hydraulic Function

TYPE	Attachment Capacity Q/kgs	Load center BP/mm.	Class FEM	Platen Dimension AxB/mm.	Overall Width l/mm.	Weight W/kgs.	Thickness LL	Center of Gravity CG
TF16A6X TF16B6X	1.600	600	-	1.220 x 355	860 1.000	325	160	210
TF20A6X TF20B6X	2.000	600	-	1.220 x 355	860 1.000	350	165	235

Hydraulic Requirement

TYPE	Oil Flow (L/min.)			Oil Pressure (kgs/cm ²)	
	Min.	Recom.	Max.	Recom.	Max.
TF	15	25	35	130	160

Fork Dimension

TYPE	Size in mm		Length in mm			Fork position in mm (Inside) (Outside)	
	Recom.	Max.	Min.	Recom.	Max.	Min.	Max.
TF	130x40	140x45	1050	1100	1200	410	710

IMPORTANT :

"EASYSIDER" must be hooked-on and supported by forks of suitable capacity fitted to the truck.

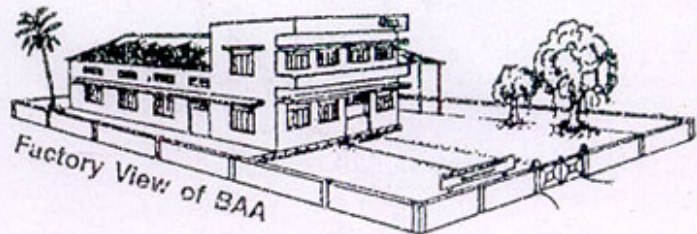

Due to our policy of constant improvement, specifications are subject to change without notice.

Designed, Manufactured & Marketed by :

BHASKARA ADVANCED AUTOMATION

Plot No.501, 4th Cross, 10th Main, 4th 'C' Phase, Peenya Industrial Area, Bangalore - 560 058.

